



Power Inverter

Inverter Telecommunications

User Manual

Sine Wave Inverter Power Supply



User Manual

Preface

For the inverter power supply equipment has high voltage able to endanger personal safety, please carefully read relevant contents of this Manual before installing and using the equipment.

【Notices】

Before operation, please carefully read this User Manual to understand the correct use method of the equipment. After reading, please properly preserve it for further inspection.

Warning: the machine shall be installed by the trained technical personnel. Before installation, please be sure to clearly understand the following issues:

- ◆ **Whether the voltage provided by DC bus is the rated DC input voltage of the inverter power supply.**

Usually, the red wire is connected to the positive electrode of the battery pack while the black wire is connected to the negative electrode of the battery pack. Please be sure to connect the DC bus according to “+” and “-” polarity.

- ◆ **During battery pack installation, firmly connect the battery pack according to the connection method and sequence specified in the battery installation instruction. It is forbidden to connect the positive and negative electrodes of the battery in short circuit or simultaneously contact any two binding posts of the battery or the exposed ends of the connecting wire; or else, the battery may be damaged or cause personal injury.**
- ◆ **Please notice: even if the Mains is cut off, the inverter power supply may still internally have the high voltage able to endanger personal safety.**
- ◆ **Please notice: the DC input terminal and the AC input terminal of the inverter shall be provided with air switches in order to cut off power supply for maintenance and fault.**
- ◆ **Please cautiously use it in the occasions involving life safety.**

Statement: due to the continuous updating and perfecting of products and technologies, the contents of this Manual may not be completely consistent with the practical products. Please understand this. For inquiring the updating condition of the product, please contact with the dealer.

Table of Contents

Chapter I Safety Instruction.....	2
1.1 Safety instruction.....	2
1.2 General safety protection.....	2
1.3 Battery related operation safety protection	3
Chapter II Overview	3
2.1 Introduction	3
2.2 Functions and features.....	3
2.3 Technical characteristics and parameters.....	5
2.3.1 Sine Wave series model code	5
2.3.2 Sine Wave series model list.....	5
Table I:	5
2.4 Technical characteristics and parameters.....	5
2.4.1 Technical index	5
Chapter III Structure and Principle.....	8
3.1 Hardware structure and working principle	8
3.2 Operation mode.....	8
3.2.1 AC power supply mode	8
3.2.2 DC power supply mode.....	9
3.3 Appearance and indicator light	9
3.3.1 Appearance.....	9
3.3.2 Front panel	9
3.3.3 Back panel.....	10
3.3.4 Indicator light.....	10
Chapter IV Installation and Debugging	10
4.1 Installation preparation	10
4.1.1 Tool, instrument and data	10
4.1.2 Installation environment inspection	11
4.1.3 Connecting cable.....	11
4.1.4 Unpacking and cargo inspection	12
4.2 Installation	12
4.2.1 Rack model	12
Chapter V Use and Operation.....	14
5.1 Power-on and power-off.....	14
5.1.1 The first time startup	14
5.1.2 Daily operation.....	14
5.2 Use operation.....	14
5.2.1 Startup	14
5.2.2 Shutdown	15
5.2.3 Mute.....	15
Chapter VI Operation Status and Display.....	15
6.1 Indicator light and button definition	15
6.2 Indicator light display list.....	16
6.3 Specification for LCD display menu	16
Chapter VII Alarm and Monitoring	18
7.1 Remote control and alarm	18
7.1.1 Interface definition	18
7.2 Common fault handling.....	19
7.3 Case structure chart	20
7.3.1 1-3KVA case size and hole size chart:	20
7.3.2 4-6KVA case size and hole size chart:	20
Quality Warranty Card.....	21
User Information Form.....	21

Chapter I Safety Instruction



Warning!

Before installing and using this inverter power supply, please carefully read the following safety instructions.

1.1 Safety instruction

The equipment has high temperature and high voltage, and shall be only installed, operated and maintained by the qualified and trained professionals. During equipment installation, operation and maintenance, it is necessary to abide by the local safety codes and relevant operation instructions; or else, personal injury or equipment damage may occur. The safety precautions mentioned in this Manual can be only regarded as the supplementation for the local safety codes.

This Company shall not bear any responsibility for the accidents caused by the violation of the general safety operation requirements or the safety standards for equipment design, production and use.

1.2 General safety protection

1. Do not expose the inverter power supply in the environment including water, fog, snow, dust, etc., and do not block or shield ventilating duct in order to reduce the danger occurrence probability. Do not install the inverter power supply in small and narrow unventilated space, or else the power supply will be overheated.
2. In order to avoid fire and electric shock, please be sure that all cables have good electrical characteristics and suitable diameter. It is forbidden to use damaged or small-diameter cables.
3. Since the parts inside the power supply may cause electric charge and striking, please do not put battery, inflammable product or any article with fire prevention requirements around the power supply.

1.3 Battery related operation safety protection

4. In case skins or clothes are contaminated by the acid liquor of the battery, please immediately use soap and clean water for washing. In case acid liquor is splashed into eyes, please immediately use cold water to wash the eyes for at least 20 minutes and then timely go to hospital for treatment.
5. Do not smoke or make open fire around the battery or the engine.
6. Do not place metal tool on the battery, because the generated spark or short circuit may cause explosion.
7. When operating lead-acid storage battery, do not wear ring, bracelet, necklace, watch and other metal ornaments, because the current at the short circuit connection of these ornaments and the storage battery may cause high temperature and accordingly melt metal and cause severe burn injury.

Chapter II Overview

2.1 Introduction

dedicated sine wave inverter is especially designed and produced for the enterprises in electrical power system and post and telecommunication industries according to their actual requirements under the condition of not only considering the spatial installation size and the automation and networking requirements for the inverter management in IT age, but also considering the influence of the noise on the personnel in offices or in machine rooms.

The inverter of this series employs advanced SPWM and CPU control technology to realize precise control, isolated input and output, output soft start, safety and high efficiency, good reliability and strong impact resistance to inductive load. Not only with small volume, light weight, beautiful appearance, convenient installation and maintenance, simple operation, low noise, low backward noise and no pollution, but also with the function of real-time data collection and multi-path remote communication, the products of this series can provide convenience for many system users to implement network management and remote control. Meanwhile, such inverter is not only applicable to communication industry, but also applicable to other occasions with high requirements for power supply quality, thus becoming the ideal selection of the power supply for office automation.

2.2 Functions and features

- This series refers to the intelligent dedicated inverter power supply and employs intelligent microcomputer CPU control technology and advanced control theory as well mature and stable high-frequency inversion mode in order to rapidly respond to the external environment change and constantly provide the high-quality AC output in a real-time manner.

- Such inverter employs advanced PWM+SPWM pulse width modulation technology to realize output soft start, and the output thereof is the pure sine wave with stable frequency and voltage, filtered noise and low distortion factor.

- Different from other false isolation mode, the advanced DC-AC electric isolation technology can really realize the completely electric isolation of DC and AC in all circuits and accordingly meet the isolation requirements of all application systems as well as eliminate all possible mutual interferences.

●This product has startup self-inspection function, strong loading capability and good load compatibility; the built-in by-pass switch has improved the continuity and reliability of the inverter power supply.

●This product also has direct startup function by mains and allows the users to provide power supply to the load through the by-pass mains when there is no DC input; meanwhile, it also allows to cut off DC under startup status and to automatically switch to the mains by-pass, without influencing the power supply for the load while facilitating the maintenance replacement of the storage battery.

●This product also has intelligent unattended operation function, namely: after the output is cut off due to too high or too low DC voltage, mains failure, etc., the power supply can automatically recover the output when the DC voltage or the mains returns to normal condition. Therefore, this product is especially suitable for the unattended communication base.

●This product has perfect safety protection functions, such as DC input inverse connection prevention and DC input buffering protection and other comprehensive protection measures for overvoltage, overload, short circuit, over-temperature and inverter fault.

●Due to the adoption of the advanced backward noise suppression techniques, this product does not mutually intervene with the communication equipment sharing the DC cabinet. The AC input terminal employs multiple filtering to eliminate the interference of the utility power grid in order to meet the requirements of the application system for AC-dominated power supply.

●This product can flexibly set AC-dominated power supply and DC-dominated power supply (such power supply form can be switched through LCD panel or communication background software):

➤When there is mains, AC-dominated inverter power supply is under mains output mode; in case of mains fault, AC inverter power supply automatically switches to inverter output.

➤DC-dominated inverter power supply is under inverter output mode during normal operation, and automatically switches to mains by-pass output during the occurrence of DC input fault.

●This product also has the function of LED+LCD status display, alarm signal display and alarm recording, and is provided with 128*64 lattice screen as the perfect humanized man-machine interface with blue background and white subtitles.

●This product has 5 groups of passive dry contacts respectively for DC input fault, AC input fault, overload information, by-pass information and output fault.

●This product is also provided with completely independent RS232 and RS485 communication interfaces, and supports real-time data communication function, and can use the monitoring software to monitor and control the working condition of the inverter power supply in a real-time manner.

●This product supports built-in TCP/IP communication to realize remote network monitoring and management of the inverter power supply.**(Optional)**

●This product supports built-in SNMP communication to realize the interconnecting function of the inverter power supply and attain the objective of network monitoring and management.**(Optional)**

2.3 Technical characteristics and parameters

2.3.1 Sine Wave series model code

220/220-2KVA

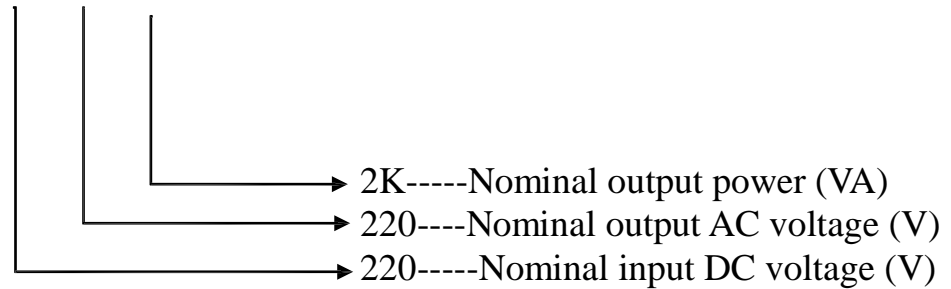

2.3.2 Sine Wave series model list

Table I:

	12 Series	24 Series	48 Series	110 Series	220 Series
500VA	12/220-0.5KVA	24/220-0.5KVA	Not available	Not available	Not available
1000VA	12/220-1KVA	24/220-1KVA	48/220-1KVA	110/220-1KVA	220/220-1KVA
2000VA	Not available	24/220-2KVA	48/220-2KVA	110/220-2KVA	220/220-2KVA
3000VA	Not available	24/220-3KVA	48/220-3KVA	110/220-3KVA	220/220-3KVA
4000VA	Not available	24/220-4KVA	48/220-4KVA	110/220-4KVA	220/220-4KVA
5000VA	Not available	24/220-5KVA	48/220-5KVA	110/220-5KVA	220/220-5KVA
6000VA	Not available	Not available	48/220-6KVA	110/220-6KVA	220/220-6KVA
7000VA	Not available	Not available	Not available	Not available	Not available
8000VA	Not available	Not available	Not available	Not available	Not available
10000VA	Not available	Not available	Not available	Not available	Not available

2.4 Technical characteristics and parameters

2.4.1 Technical index

Table II:

Technical Index(VA)		0.5K	1K	2K	3K	4K	5K	6K	
DC input	Rated input voltage (Vdc)	Refer to Table III							
	Rated input current (A)	Refer to Table III							
	Allowable range of input DC voltage (Vdc)	Refer to Table III							
	Backward noise current	≤10%							
AC by-pass input	Allowable by-pass voltage (Vac)	260V-180V(±10V)							
	Rated input current (A)	2.3	4.5	9.1	13.6	18.2	22.7	27.3	
	By-pass conversion time (ms)	≤5ms							
AC output	Rated capacity (VA)	500	1K	2K	3K	4K	5K	6K	
	Rated output power (W)	400	800	1600	2400	3200	4000	4800	
	Inverter output voltage and frequency	230Vac, 50HZ							
	Inverter output current (A)	1.8	3.6	7.2	10.8	14.5	18.2	21.8	
	Output voltage precision (V)	230±1.5%							
	Output frequency precision (Hz)	50±0.1% Or 60±0.1%							
	Waveform	Pure sine wave							
	Total harmonic distortion (THD)	≤3% (linear load)							
	Dynamic response time	5% (load 0←→100%)							
	Power factor (PF)	0.8							
	Overload capacity	100%-120% 60s			121%-150% 10s				
	Inversion efficiency (80% resistive load)	≥85%							
	By-pass conversion time (ms)	≤5ms							
Working environment	Dielectric strength (input and output)	1500Vac, 1 minute							
	Noise (1m)	≤40dB							
	Operating environment temperature	-20℃~+50℃							
	Humidity	0~90%, no moisture condensation							
	Operating altitude (m)	≤2000							
Indication	LCD display	Input and output voltage, frequency, output current, temperature, percentage, etc.							
	inverter status	Normal mains, normal inversion, battery under-voltage and output overload							
Mechanical size	Standard rack (Depth × Width × Height) (mm)	Refer to 7.3 Case Structure Chart							

Protection function	Input under-voltage and overvoltage, output overload and short circuit protections, etc.
---------------------	--

Table III:

	12 Series		24 Series		48 Series		110 Series		220 Series	
Rated input voltage (Vdc)	12V		24V		48V		110V		220V	
Allowable range of input DC voltage (Vdc)	Cutoff voltage 10V—15V		Cutoff voltage 20V—30V		Cutoff voltage 40V--60V		Cutoff voltage 90V—139V		Cutoff voltage 180V--275V	
	Startup voltage 11V—14V		Startup voltage 22V—28V		Startup voltage 45.5V—57V		Startup voltage 104V—131V		Startup voltage 208V—260V	
Rated input current (A)	0.5KVA	42	0.5KVA	21	Not available		Not available		Not available	
	1KVA	83	1KVA	42	1KVA	21	1KVA	9	1KVA	4.5
	Not available		2KVA	83	2KVA	42	2KVA	18	2KVA	9
	Not available		3KVA	125	3KVA	63	3KVA	27	3KVA	13.5
	Not available		4KVA	167	4KVA	83	4KVA	36	4KVA	18
	Not available		5KVA	20	5KVA	104	5KVA	45	5KVA	22.5
	Not available		Not available		6KVA	125	6KVA	55	6KVA	27
	Not available		Not available		Not available		Not available		Not available	
	Not available		Not available		Not available		Not available		Not available	
	Not available		Not available		Not available		Not available		Not available	

Chapter III Structure and Principle

3.1 Hardware structure and working principle

- ❖ **Specification:** such product employs advanced PWM+SPWM high frequency technology and takes CPU as the master control chip, thus realizing the perfect combination of the advanced intelligent control and the mature and stable inverter mode.

Functional block diagram

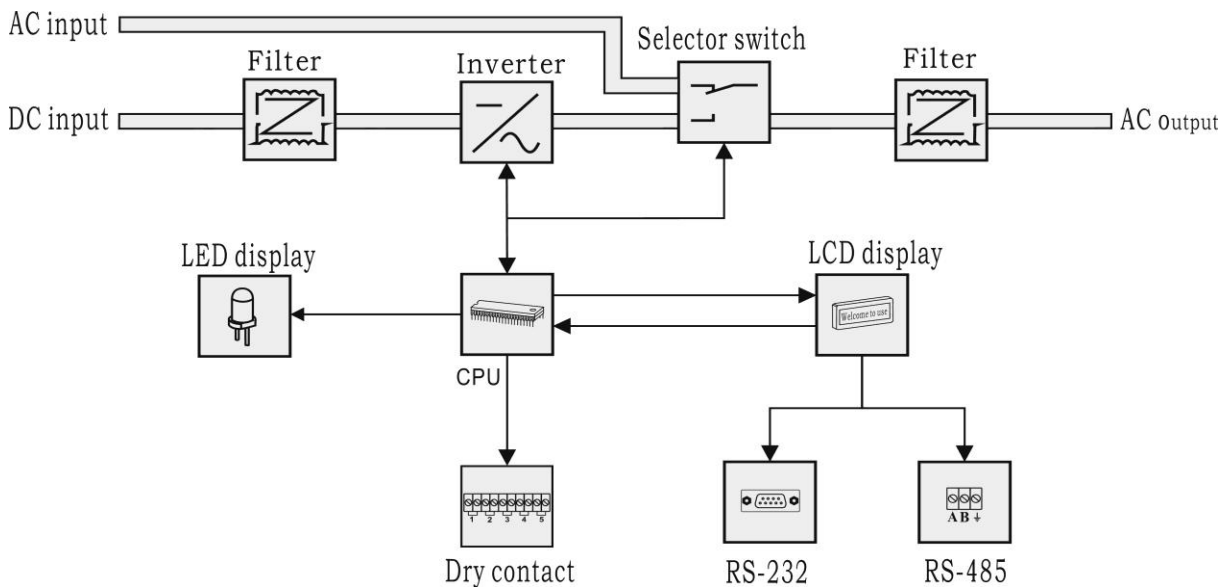

3.2 Operation mode

3.2.1 AC power supply mode

- ❖ Namely AC inverter working mode: the inverter employs mains for load when there is mains and switches to inverter working mode when the mains is abnormal.

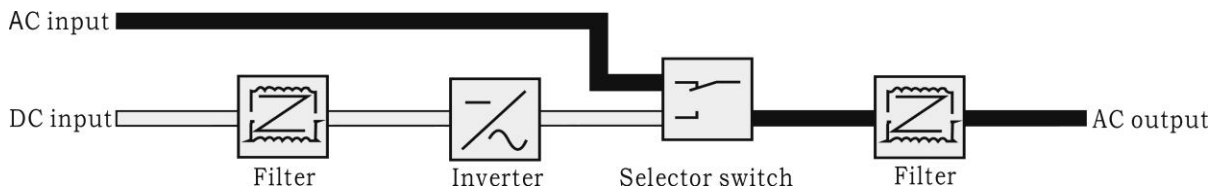

3.2.2 DC power supply mode

- ❖ Namely DC-dominated inverter working mode: under normal condition, DC-dominated inverter is under inverter output status all the time; in case of DC fault, it switches to mains by-pass.

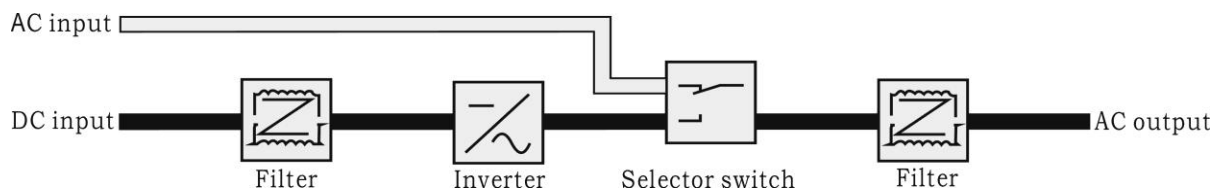

3.3 Appearance and indicator light

3.3.1 Appearance

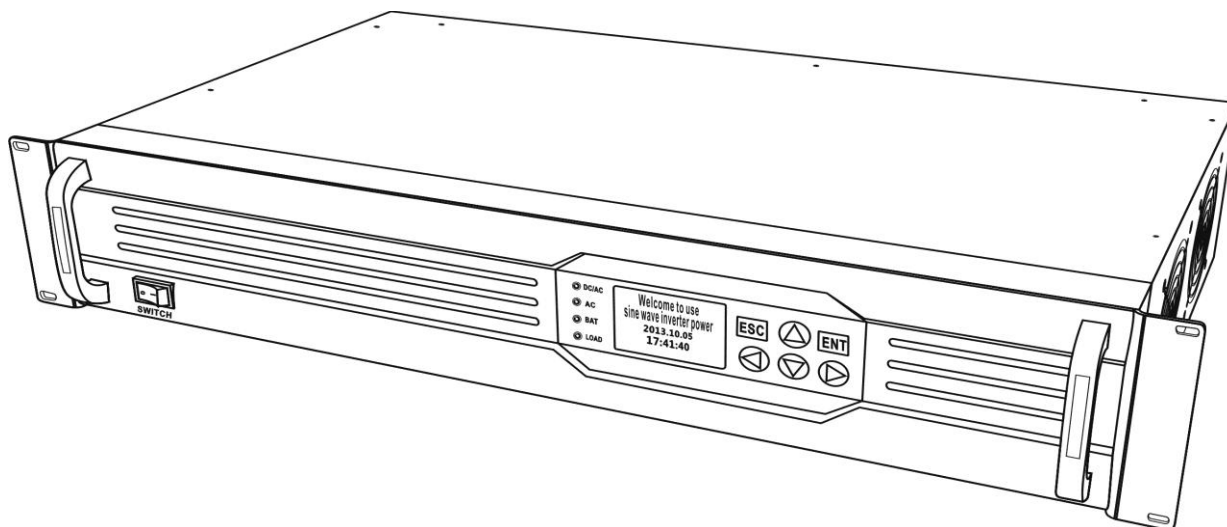

3.3.2 Front panel

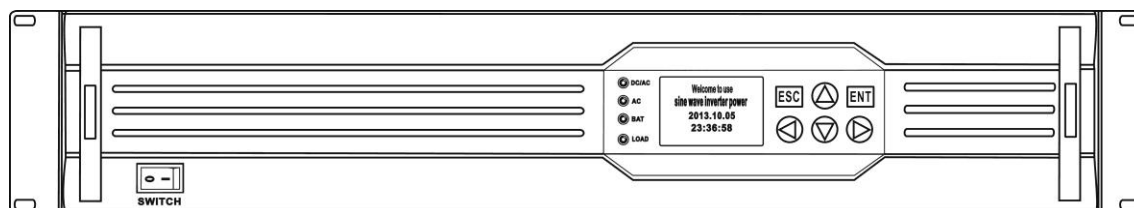

3.3.3 Back panel

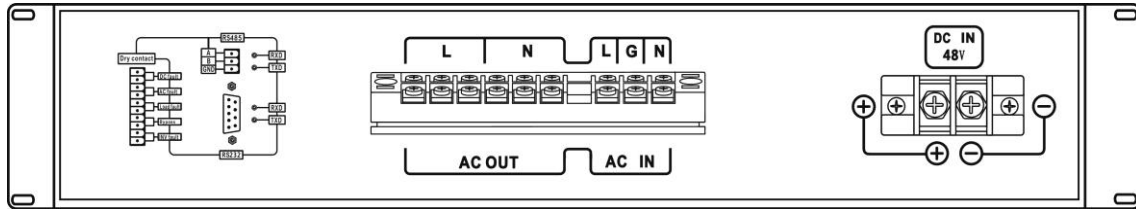

3.3.4 Indicator light

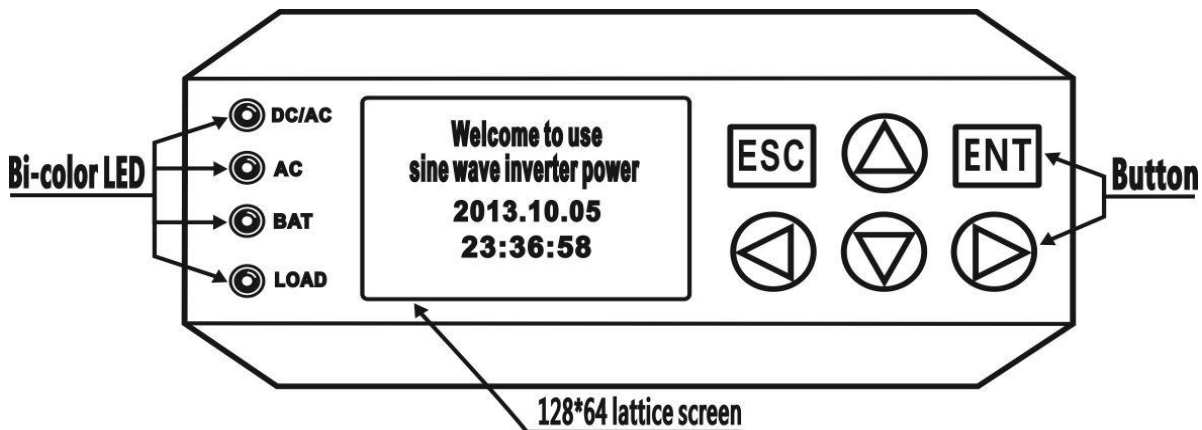

Chapter IV Installation and Debugging

4.1 Installation preparation

- ❖ *Such inverter power sully must be installed only by the technical personnel with certain electric theory knowledge and practical experience.*

4.1.1 Tool, instrument and data

4.1.2 Installation environment inspection

Environmental requirements

- Working temperature: $-20^{\circ}\text{C} \sim +50^{\circ}\text{C}$
 - Storage temperature: $-40^{\circ}\text{C} \sim +70^{\circ}\text{C}$
 - Relative humidity: 0%-95%, no moisture condensation
 - Cooling mode: temperature control type air cooling
 - Altitude: 1500m, meeting the derating requirement of GB3859.2-93
 - Verticality: no vibration, with the vertical gradient not exceeding 5 degrees
 - Class of pollution: Class II
- ❖ The system shall be installed in the cool and dust-free operating environment with sufficient ventilation and relatively low humidity. The recommendable working temperature is $20 \sim 25^{\circ}\text{C}$ and the humidity shall be controlled at about 50%.

Attention

**Inflammables, explosives or corrosive gas or liquor shall not be stored in the room.
It is forbidden to be installed in the working environment with metallic conductivity dust.**

4.1.3 Connecting cable

- ❖ AC input cable: users can optionally select and configure the cable and meanwhile the connector is randomly provided as the connecting wire. The cable specification is as shown in the following table:

Capacity	Cable Section Area
500VA	0.75mm^2
1000VA	1.5mm^2
2000VA	2.5mm^2
3000VA	4.0mm^2
4000VA	4.0mm^2
5000VA	6.0mm^2
6000VA	6.0mm^2

- ❖ AC output cable: users can optionally select and configure the cable.
- ❖ DC input cable: users can optionally select and configure the cable, and fabricate the connector. In order to ensure the electrical safety, please refer to the following table for wiring selection:

Capacity	Wire Section Area				
	12V	24V	48V	110V	220V
500VA	16 mm ²	6.0 mm ²	4.0 mm ²	2.5 mm ²	1.5 mm ²
1000VA	25 mm ²	10 mm ²	6.0 mm ²	4.0 mm ²	2.5 mm ²
1500VA	No	16 mm ²	10 mm ²	6.0 mm ²	2.5 mm ²
2000VA	No	20 mm ²	16 mm ²	6.0 mm ²	2.5 mm ²
3000VA	No	50 mm ²	16 mm ²	10 mm ²	4.0 mm ²
4000VA	No	50 mm ²	25 mm ²	16 mm ²	6.0 mm ²
5000VA	No	50 mm ²	36 mm ²	25 mm ²	6.0 mm ²
6000VA	No	No	36 mm ²	25 mm ²	10 mm ²

4.1.4 Unpacking and cargo inspection

- ❖ The equipment shall be placed in the satisfactory storage environment and the storage period shall preferably not exceed 3 months.
- ❖ During equipment installation, it is necessary to deliver the equipment to the installation site and then remove the external package. At this moment, it is necessary to check whether the equipment and materials are correct according to the packaging list inside the container and meanwhile properly preserve various spare parts and accessories for installing, updating and maintaining the equipment in future.

4.2 Installation

4.2.1 Rack model

1. Handle installation

After removing the package, take out the valve bag containing two L-shaped handle frames and handles from the installation accessories, use M4 screw in the bag to fix the right and left sides of the inverter power supply and meanwhile lock the screw, as shown in the following figure:

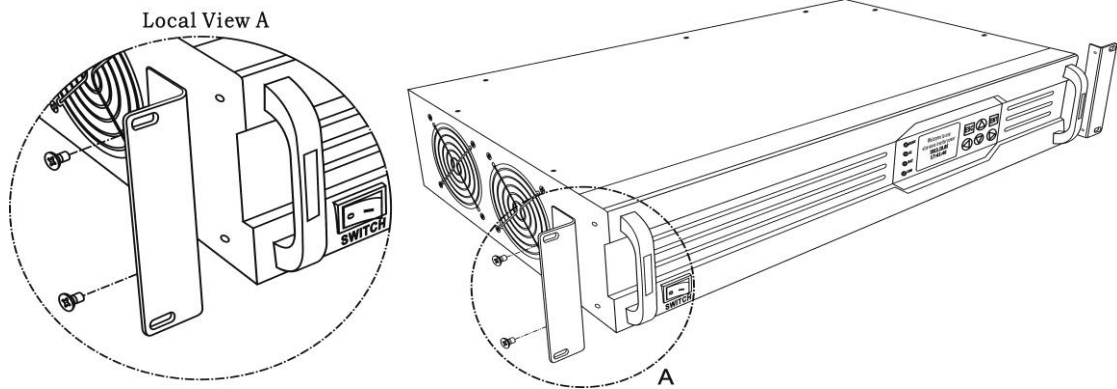

2. Placement and fixation

Place the inverter power supply installed with handles at the position suitable for 19-inch rack (notice: the inverter power supply shall be provided with supporting device at the bottom!) and then fix it.

3. Connecting cable

1) DC input connection

Connect the prepared cable to the DC input terminal at the back part of the inverter power supply and pay attention to the connection of the positive and negative electrodes.

Hot-line operation shall be forbidden in order to avoid such accidents as short circuit and striking which may endanger personal safety and equipment safety.

2) AC input and output connection

Terminal strip is adopted for the AC input and output connection of this machine. It is necessary to well connect the cables with connectors according to the silk-screen mark.

Notice: the live line and the null line cannot be inversely connected, and the input and the output cannot be inversely connected; after wire connection, it is necessary to check whether the wires are firmly and stably connected, as shown in the following figure:

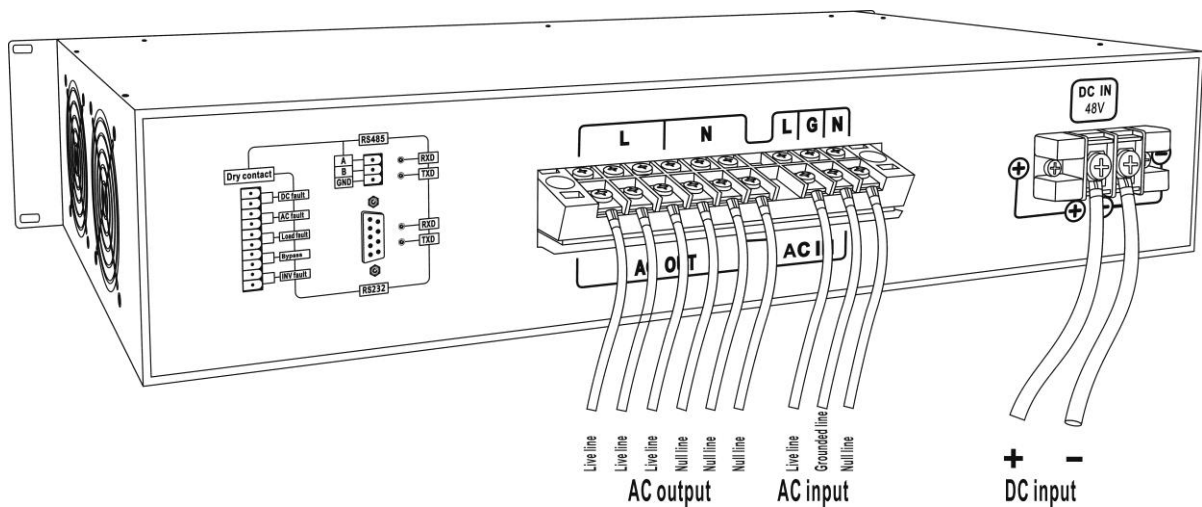

Chapter V Use and Operation

5.1 Power-on and power-off

5.1.1 The first time startup

- Check whether the DC input voltage is consistent with the label at the back of the machine; in case of any inconsistency, please do not introduce DC power supply in order not to cause machine damage! For any unclear part, please contact with the supplier or directly contact with the manufacturer.
- Check whether the wiring polarity of the DC input is correct; or else, the machine cannot be normally started.
- Check whether the wiring of AC input and output is correct and confirm that there is no short circuit phenomenon.
- If there is no error in the above checks, respectively introduce DC power supply and AC power supply.
- Place the startup switch on the machine at NO position in order to send power to start the machine.
- Firstly, all indicator lights are orderly turned on for self-inspection.
- Then, the output relay is closed to output AC power supply to the load.

5.1.2 Daily operation

- Only the startup & shutdown switch on the machine is operated for daily startup.
- For shutdown, it is necessary to firstly turn off the load and then turn off the inverter switch.
- For long-term nonuse, please cut off the power supply for AC input and output as well as the output connection in order to ensure safety.
- Please follow the operations for the first time startup to start the machine after long-term nonuse.

5.2 Use operation

5.2.1 Startup

1. Confirm whether DC input and AC output of the power supply are correctly and reliably connected;

2. After the startup/shutdown switch is rightwards pressed, the inverter sends “tick” noise and enters self-inspection status, thus indicating that the machine is started.

Self-inspection status: before steady output, the inverter power supply checks the external environment and checks whether the inverter supply power itself is normal; if various status parameters of the inverter power supply and the mains are normal, the inverter will steadily operate in mains status or inverter status (AC-dominated inverter is steady in mains output status and DC-dominated inverter is steady in inverter output status). It takes about 5s to complete this process.

5.2.2 Shutdown

After the startup/shutdown switch is leftwards pressed, the inverter LED indicator light and the inverter power supply are both turned off.

5.2.3 Mute

In case the inverter power supply has fault in the operation process, the system will send audible and visual alarm which can be set through LCD, namely selecting Turn Off (such turn-off is **permanent**, and there will be no audible alarm for any new fault) in the sound control option.

Operator can directly press **ENT (temporary)** button to inactivate and activate (the existence of alarm is the essential condition) the alarm. For the same alarm, the muted alarm will not be automatically turned on (if the fault is removed and the same fault appears again, the alarm will be turned on again); if there is another alarm, no matter whether the last alarm is under mute status or not, the system will automatically turn on the audible alarm.

Chapter VI Operation Status and Display

6.1 Indicator light and button definition

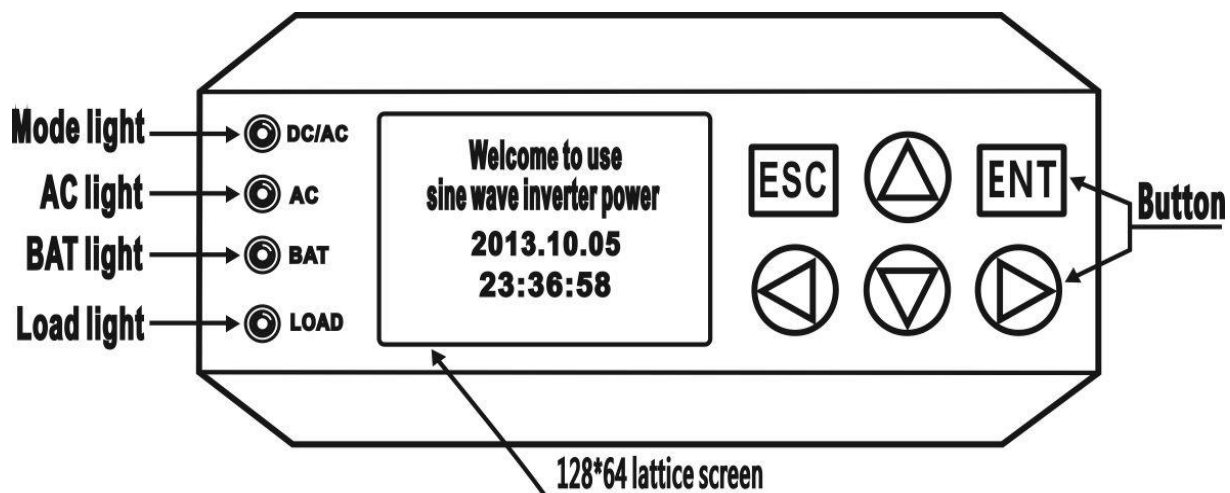

6.2 Indicator light display list

Startup self-inspection	Status	Mode (Green) →On→	Mains (Green) →On→	Battery (Green) →On→	Load (Green) →On→		
	Buzzer	One sound every 1s, and triple sounds before mute.					
Mode light (Green/Blue)	Status	AC mode	DC mode				
	Indicator or light	Normally green	Normally blue				
	Buzzer	No	No				
Mains Light (Green/Red)	Status	Normal AC voltage	High AC voltage	Low AC voltage	No AC voltage		
	Indicator or light	Normally green	Quick flashing red	Slow flashing red	Normally red		
	Buzzer	No	One sound every 3s	One sound every 3s	One sound every 3s		
Battery light (Green/Red)	Status	Normal DC voltage	High DC voltage	Low DC voltage	No DC voltage		
	Indicator or light	Normally green	Quick flashing red	Slow flashing red	Normally red		
	Buzzer	No	One sound every 1s	One sound every 3s	One sound every 3s		
Load light (Green/Red)	Status	Normal load	Overload 120%	Overload 150%	Overload shutdown	Short circuit shutdown	Inverter fault
	Indicator or light	Normally green	Slow flashing green	Quick flashing green	Slow flashing red	Quick flashing red	Normally red
	Buzzer	No	One sound every 1s	One sound every 1s	Continuous sound	Continuous sound	Continuous sound

6.3 Specification for LCD display menu

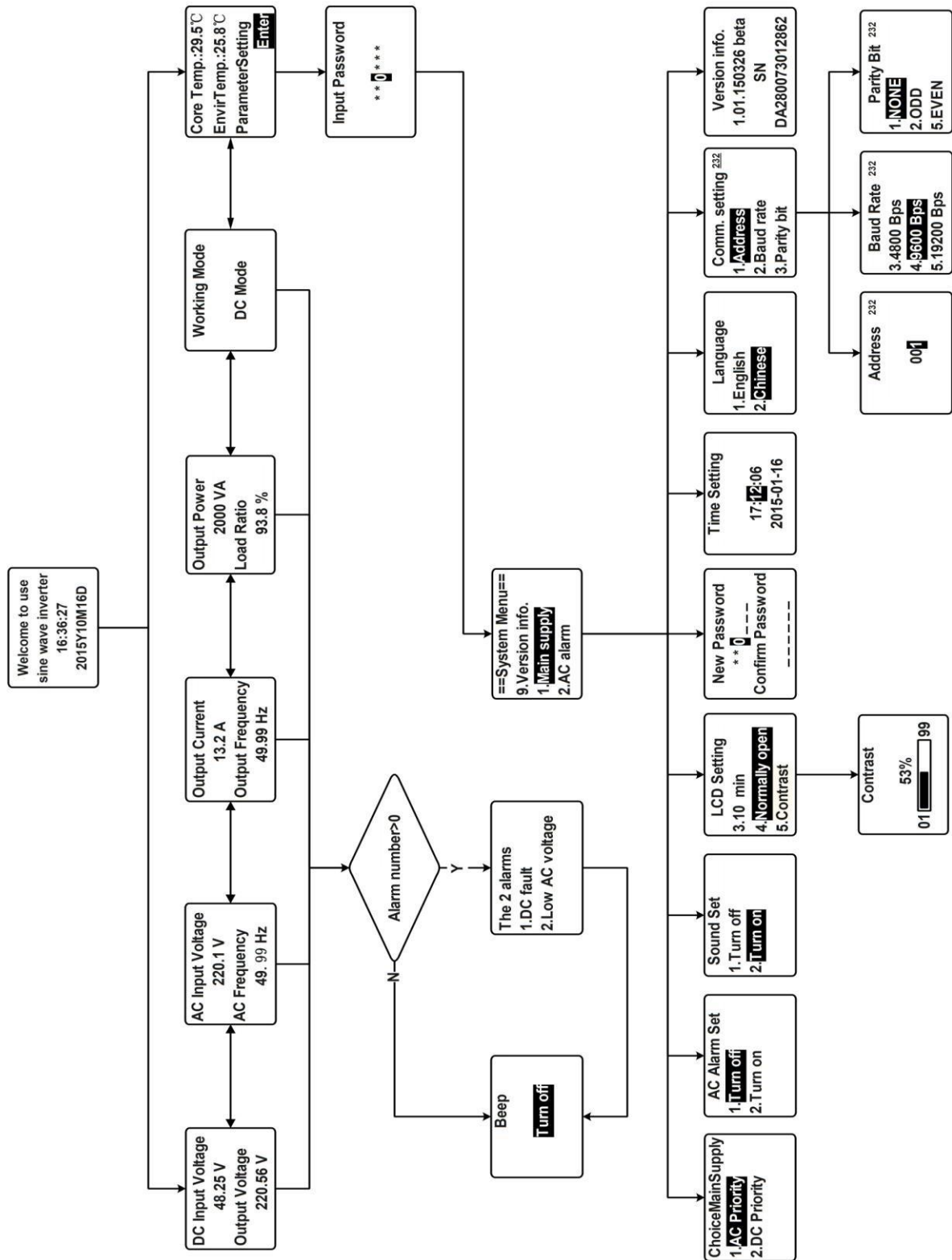

Chapter VII Alarm and Monitoring

7.1 Remote control and alarm

7.1.1 Interface definition

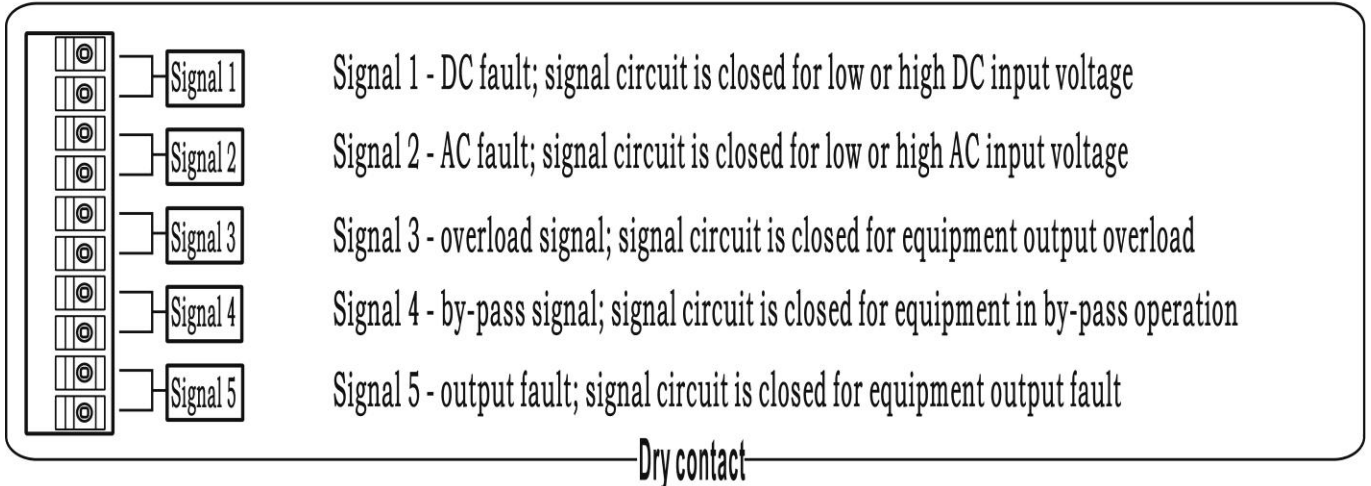
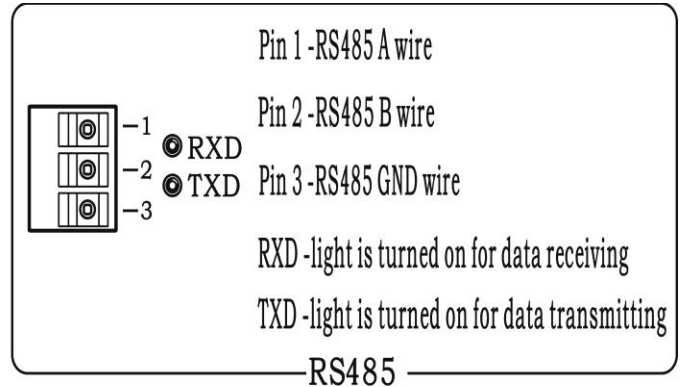
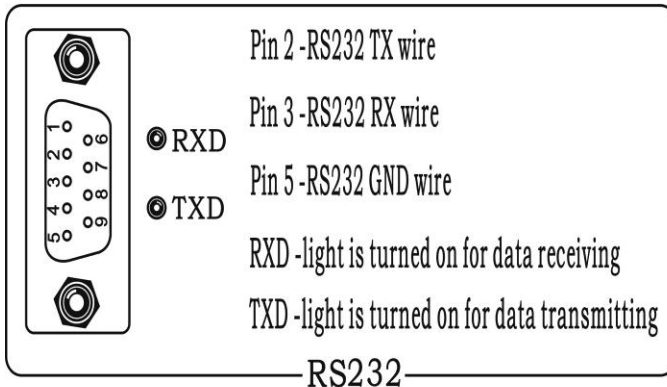

Note: the contact capacity of each group of the dry contacts shall not exceed 60 V 0.5A.

7.2 Common fault handling

Fault Type	Fault Phenomenon	Fault Analysis	Fault Point Judgment	Fault Handling	Remarks
Startup fault	Unable to start up	Inverse connection of DC negative and positive electrodes	Check the negative and positive electrodes of DC input terminal before connection, wherein the high potential shall be connected to “+” electrode while the low potential shall be connected to “-” electrode.	Confirm the negative and positive electrodes and then reconnect the corresponding wire.	
		Low DC startup voltage	Use DC gear of the universal meter to measure the voltages of the two ends of the terminal to confirm whether the voltage is higher than startup voltage.	Start up the machine after the storage battery is charged to the startup voltage point.	
Operating fault	The machine has no output after operating for a certain period	Low-voltage or high-voltage protection of inverter; overload protection, etc.	Cut off the load to test whether the machine can normally operate and whether the voltage of each point is normal, etc.	Consult with the technical personnel of the manufacturer.	
Mains switching fault	Unable to switch	Too high or too low utility supply voltage	Use universal meter to measure AC input of inverter to check whether the voltage is within the working range.	Switch after the utility supply voltage is stable.	
		Low-voltage shutdown protection of inverter	After low-voltage shutdown of inverter, connect to the Mains without switching.	Switch after the inverter operates again.	
Output fault	No output	Machine protection	High voltage, low voltage, over-temperature, overload, etc.	Consult with the manufacturer.	
Communication fault	Unavailable communication	Whether the communication interface is wrongly accessed.	Check whether the correct communication mode (RS232 485) is selected.	Select correct communication mode	
	Unstable communication	Whether the communication line is too long.	Check whether the Baud rates of the communication line material and panel are consistent with each other.	Use twisted pair or reset Baud rate.	

7.3 Case structure chart

7.3.1 1-3KVA case size and hole size chart:

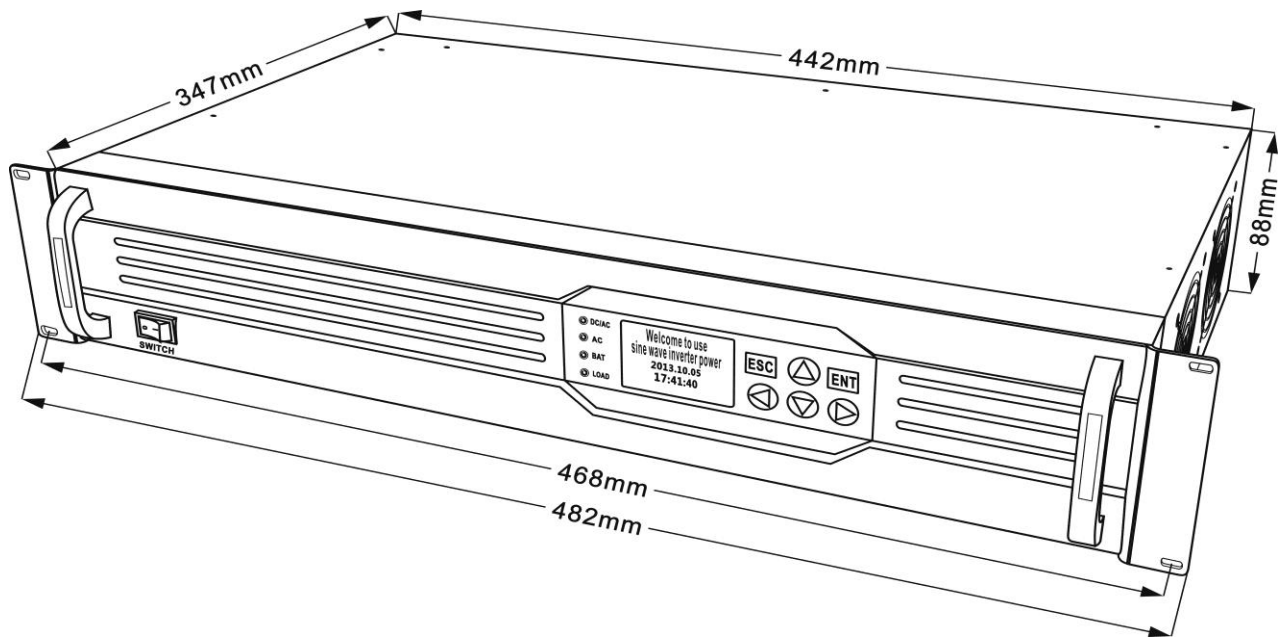

7.3.2 4-6KVA case size and hole size chart:

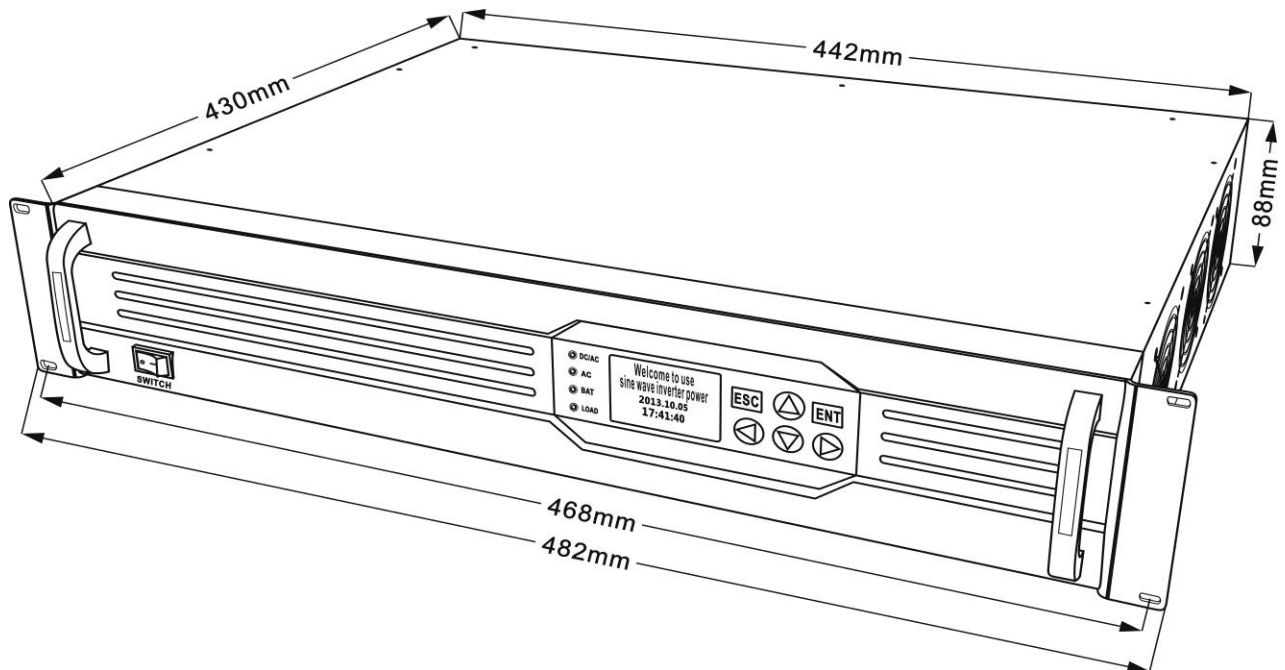

Quality Warranty Card

In order to ensure high quality, the sine wave inverter power supply must be strictly inspected before delivery. This Company assures the good machine performance and the parts integrity listed in the warranty card to the users. The free warranty service is available for one year, and the warranty regulations are as follows:

(I) In case the parts are damaged or have fault within the warranty period since the purchasing of the machine and such damage or fault has been verified by the technical personnel of the Company to take place in normal use, the Company will freely repair the machine and replace relevant parts, but the damaged parts shall belong thereto.

(II) In case of any following condition listed in the warranty card for the machine, the warranty period shall be automatically expired.

1. Alter company trademark;
2. Damage is caused due to faulty operation, use negligence and negligence factors;
3. Other persons rather than the technical personnel of the Company optionally start up the machine for repair, refit the machine, obliterate or remove machine number or seal strip;
4. The machine is not installed according to the installation instructions of the manufacturer.

(III) Please properly reserve this card and show this card and the purchasing receipt note (invoice) to the technical personnel for repair.

User Information Form

User UnitContact Person
User AddressContact Phone Number
Distribution UnitPostcode
Product ModelLocal Phone Number
Purchasing TimeResponsible Person

Maintenance Record Form

Date	Maintenance Type	Summary	Maintenance Man	User Signature

Note: please make one copy with official seal after the user information is written and send it back to the Market Department of the Company for archiving.